

## User Centered Design

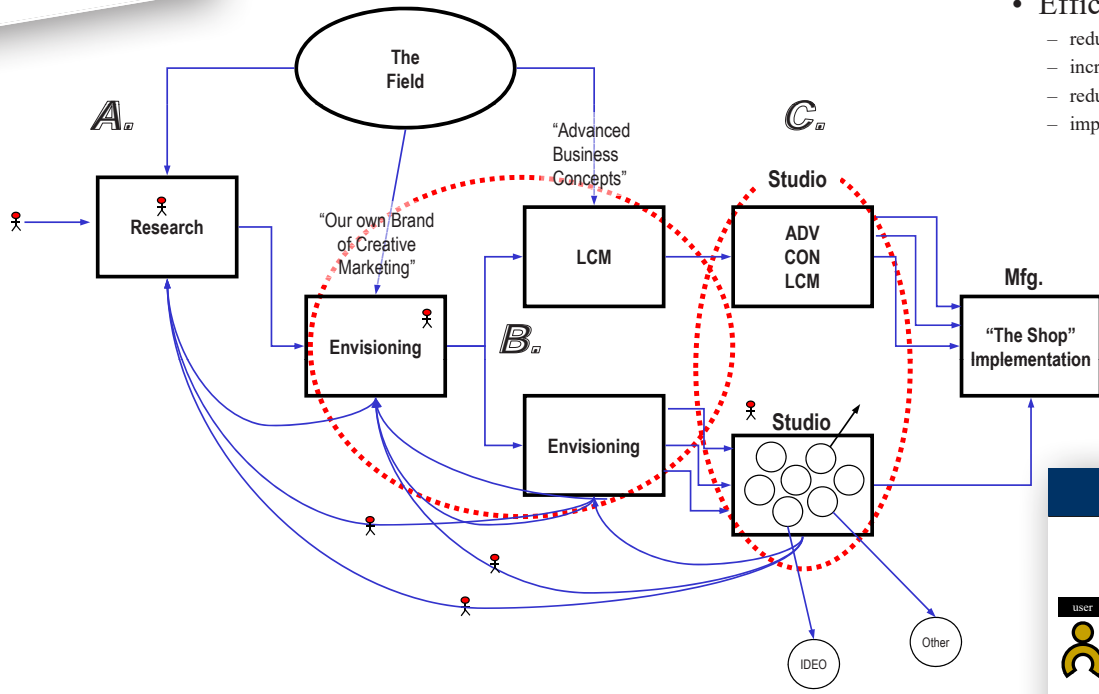

- Effectiveness
  - improve trust & social network
  - improve ability to resource strategy
  - act on our desire meet ALL user needs (explicit, latent, & emerging)
  - better manage holistic Inc. marketing plan
- Efficiency
  - reduction in user centered design costs
  - increase in number of projects through discovery/ phase 1
  - reduction in time to market from phase 2 to 3
  - improve EVA position on new & existing products and services

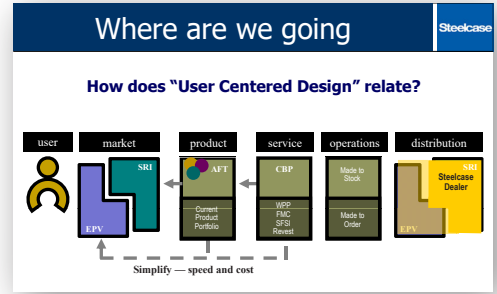

developed with:  
**Steelcase**

## User Centered Design

A global product and service development process was designed, including role/responsibility clarifications, process documentation to ensure repeatability and training to enable understanding and sustainability.